

## MILK COOLING TANK with DIRECT EXPANSION

### REM/DX 1050 - 15000 l

#### Characteristics

- ›Horizontal tank with laser welded efficient evaporator
- ›Constructed of stainless steel 18/10 – AISI 304
- ›Chassis with solid leg construction and adjustable feet (standard 2 % slope)
- ›Flat manhole and swivelling cover with rubber seal
- ›Detachable air vent
- ›2 milk inlet openings, 80 mm (1 in the manhole cover, 1 at the back)
- ›REM/DX 2100 and smaller:  
Tank outlet 50 mm, self washing outlet with butterfly valve and road tanker connection NW 50
- ›Tanks above 2100 litre:  
Tank outlet 80 mm, self washing outlet with butterfly valve and road tanker connection NW 50 or 65
- ›Other milk road tanker connections on request, e.g. SMS, DS, RJT or IDF
- ›"Self washing outlet" easy to upgrade (no welding). Increased second hand value.
- ›All models above 2100 litres are fitted with a stainless steel ladder
- ›Tank conform EN 13732 - KEYMARK label

#### Tank control and display

- ›All electrical tank components 1 ~ 230V – 50Hz (other voltages / frequencies on request)
- ›Milk temperature control with electronic operating unit DOLPHIN
- ›Digital temperature indication with large LCD display
- ›Two adjustable set points (3.2 °C and 4.5 °C)
- ›Deep cooling (1.9 °C)
- ›Full automatic logging of cooling, agitation, cleaning and possible errors

#### Cooling and agitation

- ›Thanks to the free evaporation and proper mixing of the milk the heat exchange is optimal.
- ›A high cooling capacity is guaranteed
- ›The number of agitator motors depends on the volume of the tank (see table tank dimensions)
- ›Cooling pipes pre-mounted with thermostatic expansion valve(s)



#### Cleaning

- ›2 automatic dosage cups for detergents
- ›Automatic water level control for optimal filling and low water usage
- › High pressure dynamic Packo-ROTOJET system with spray balls in agitator blade(s)
- ›Vertically mounted stainless steel cleaning pump, no risk of freezing
- ›Pump power depends on number of agitators:
  - 1 agitator: 1.1 kW, 1 ~ 230V 50Hz
  - 2 agitators: 1.5 kW, 1 ~ 230V 50Hz

#### Available options

- ›Warning messages sent by SMS
- ›Timer for manual cooling and cleaning
- ›Dosing cup(s) for detergents
- ›ECO-WASH short cleaning
- ›Tank adapted to AMS milking
- ›OCULUS tank guard to monitor all tank functions
- ›PACAP digital volume indication with LED display (see picture above)
- ›Bottom filling
- ›Flow meter alkaline detergent

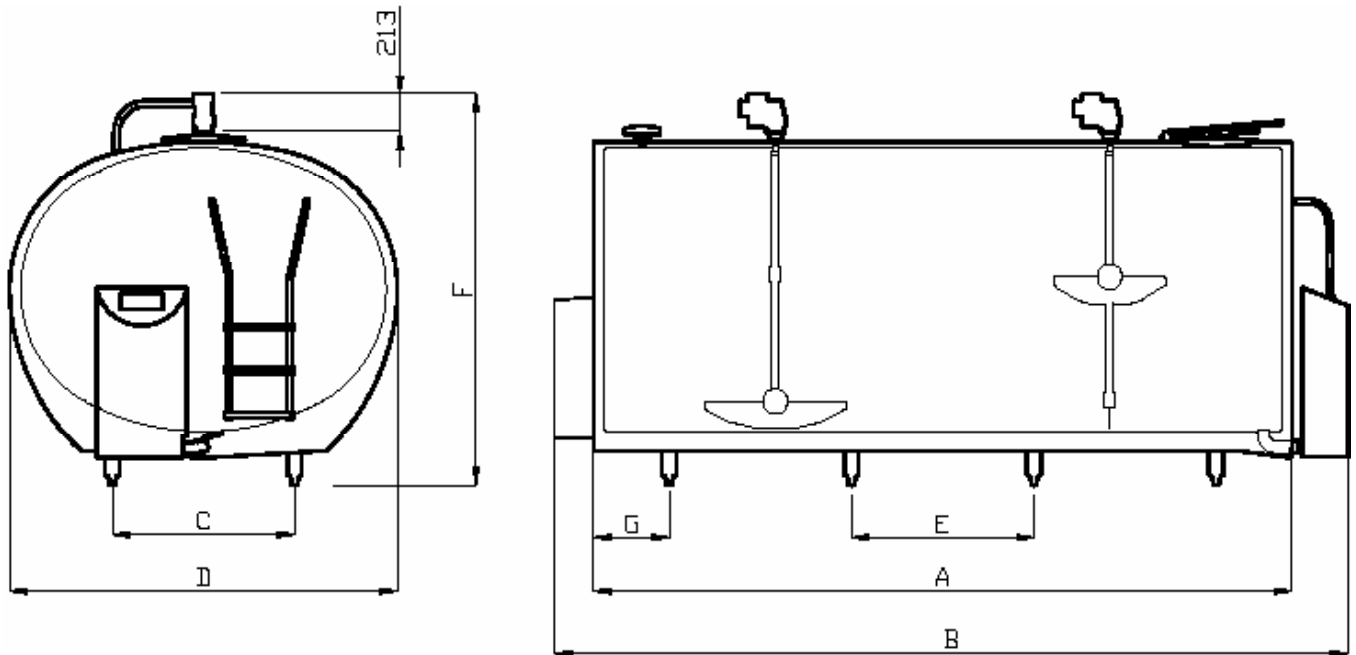

## REM/DX Dimensions

Model	Max. cap. litres	A mm	*B mm	*B+ mm	C mm	D mm	E mm	F mm	G mm	Legs number	Weight kg
1050	1125	1398	1944	2593	670	1308	932	1550-1585	233	4	220
1300	1393	1704	2250	2899	670	1308	845	1550-1585	424	4	295
1700	1715	2070	2616	3265	670	1308	1210	1550-1585	425	4	365
2100	2140	2553	3099	3748	670	1308	1690	1550-1585	426	4	412
2600	2653	1911	2458	3107	750	1660	1210	1852-1972	351	4	437
3100	3186	2271	2818	3467	750	1660	1440	1852-1972	416	4	500
3800	3944	2503	3050	3699	934	1800	1690	1840-1960	407	4	590
4400	4562	2873	3420	-	934	1800	1050	1840-1960	387	6	667
5000	5128	3213	3760	-	934	1800	1210	1840-1960	397	6	730
RS 5000	5102	2380	3026	-	1050	2100	1580	2058-2178	400	4	750
6150	6321	2894	3440	-	1050	2100	1050	2058-2178	397	6	854
7200	7369	3354	3900	-	1050	2100	1210	2058-2178	467	6	901
RS 8000	8159	3140	3686	-	1050	2233	870	2208-2328	265	8	1065
8200	8406	3809	4355	-	1050	2100	1050	2058-2178	330	8	1090
9000	9566	3681	4227	-	1050	2233	1050	2208-2328	266	8	1160
10000	10482	4021	4557	-	1050	2233	1050	2208-2328	436	8	1229
12000	12602	4810	5356	-	1050	2233	1050	2208-2328	305	10	1450
15000	15762	5986	6532	-	1050	2233	1050	2208-2328	368	12	1800

B+ : with cooling unit incorporated.

\*With ECO-WASH: B + 190 mm.

REM/DX available in 2, 4 & 6 Milkings and AMS milking.

RS/DX available in 4 & 6 Milkings and AMS milking.

REM/DX 1050-5000: 1 agitator incorporating 1 rotojet spray ball.

REM/DX 6150-8000: 1 agitator incorporating 2 rotojet spray balls.

REM/DX 8200-15000: 2 agitators incorporating 4 rotojet spray balls.

Subject to modifications. The photographs and descriptions provided are intended as a guide and may not always exactly match the items supplied.

